

Item	Criteria
Operating Force(OF)	180gf Max.
Free Position(FP)	10.7mm Max.
Operation Position(OP)	8.5±0.4mm △

Ratings	Datas(resistive load)	Operating life with load
	5VDC 1mA	300,000 Cycles Min.
	12VDC 50mA	200,000 Cycles Min.
	16VDC 50mA	150,000 Cycles Min.
Contact Resistance:	500mΩ Max. (Initial)	
Insulation Resistance:	100MΩ Min. 500VDC (Initial)	

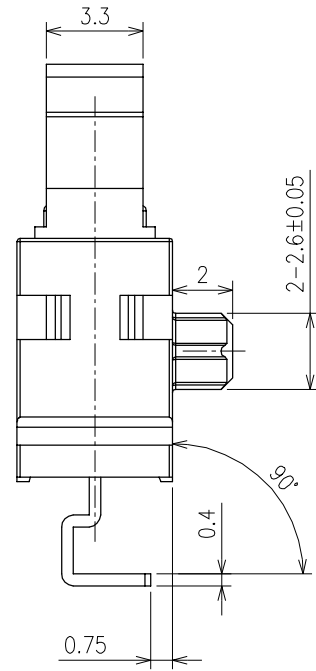
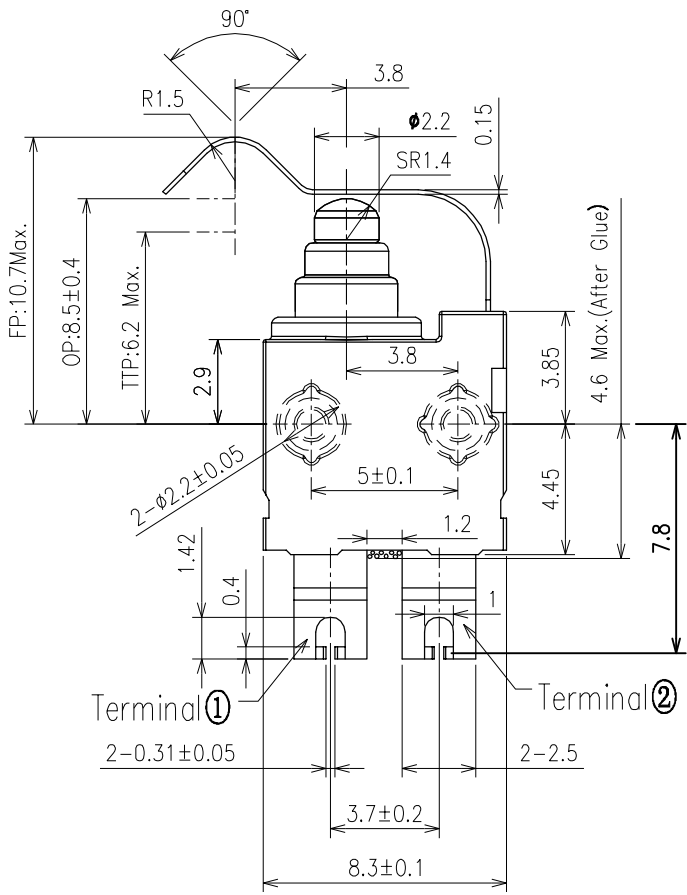

Protection Class:	IP67(Except terminal)
Operating life without load	500,000 cycles
Operating Temperature Range:	-40~+85℃

Seal Rubber	Silicon Rubber(Green)
Switch Housing	Thermoplastics PBT
Switch Base	Thermoplastics PBT
Terminals	Copper Alloy, Silver plated
Actuator	Thermoplastics POM
Slide Contact	Copper Alloy
Spring	Stainless Steel

Note: Refer to specification MQS-9B1AR04-A2-SPC.001

NOT FOR MASS PRODUCTION

REV.	DATE	MODIFICATION	ECN NO.	PRIOR VERSION
Project Ref:		MQS-9B Series Micro Switch	Tolerance Unless Otherwise Specified	
Part No:		MQS-9B1AR04-A2	-3	>3-10 >10-30 >30-80 >80-180 >180
Drawing No:		---	Eng Ver	A0X1
Drafted by:		Moon Lin	Date:	2021-02-22
Checked by:		Jerry	Date:	2021-02-22
Approved by:		Norris Xie	Date:	2021-02-22
Unit: mm			Size: A4	Scale: 4:1
THIRD ANGLE			TONELUCK Switches & Control Solutions	