

File/Edition: MQS-9A1HC-A1-SPC.001

Description: Micro Signal Switch

Customer Name: Model No.: MQS-9A (Series)

Customer P/N: Toneluck P/N: MQS-9A1HC-A1

Representative: Project Code:

Specifications Receipt Confirmation

Received by: _____

Title: _____

Signature: _____

Date: _____

Remark:

1. This product specification is considered as the technical agreement between the receiving customer and Toneluck. Any information on the general product catalog which is in conflict with or different from the corresponding information of this document is considered as invalid.
2. If customer issue purchase orders without confirmation by signature of this specification after receipt, such confirmation will be considered as granted upon receipt of the first purchase order.

Prepared by: Zengjiong Wu 2022-03-09Checked by: Jerry 2022-03-09Approved by: Norris Xie 2022-03-09

Customer P/N:	Toneluck P/N: MQS-9A1HC-A1	Project Code:
Version: A1	Issued Date: 2022-03-09	Page 1 of 8

1. General

1.1 Application: This specification is applied to low current circuit (secondary circuit) detector switch used for electronic equipment.
1.2 Operating temperature range: -40°C ~ +85°C
1.3 Storage temperature range: -40°C ~ +85°C
1.4 Test conditions: Unless otherwise specified, the atmospheric conditions for making measurements and tests are as follows. Ambient Temperature : 5~35°C Relative Humidity : 25~85% Air Pressure : 86~106kPa Should any doubt arise in judgment, tests shall be conducted at the following conditions. Ambient Temperature : 20±2°C Relative Humidity : 60~70% Air Pressure : 86~106kPa

2. Appearance, Structure & Dimensions

2.1 Appearance :	The switch shall have good finishing, and no rust, crack or plating defects.
2.2 Structure & Dimensions :	Refer to individual product drawing.
2.3 Markings :	Refer to individual product drawing.

3. Ratings & Life

Rating	Operating Life with Load	Operating Life without Load
Refer to individual product drawing.		

4. Electrical specification

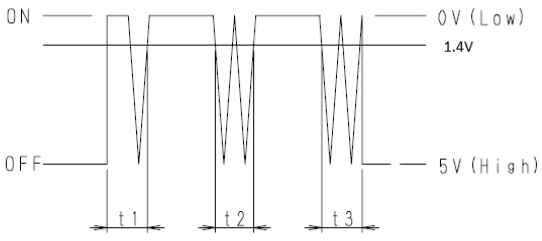
Item	Test conditions	Criteria
4.1 Contact resistance	Shall be measured at 10mA, 5V by voltage drop method (The root of terminal shall be measured)	500 mΩ Max.
4.2 Insulation resistance	Test voltage: 500 VDC, measured after 1 min±5 s Applied position: Between all terminals Between terminals and ground	100 MΩ Min.
4.3 Voltage proof	Test voltage: 500 VAC(50-60Hz, cut-off 2mA) Duration: 1 min Applied position: Between all terminals Between terminals and ground	No dielectric breakdown shall occur
4.4 Contact chattering and bouncing	Measured at the operation speed of 50mm/s, 5VDC 1mA  Resolution of measuring equipment shall be 200 μs.	t1,t2,t3 shall be defined the voltage fluctuation time exceeding 1.4 V. Contact chattering t1,t3 10ms Max. Contact bouncing t2 10ms Max. When 250μs interval less than 1.4 exists between each bouncings, the bouncings shall be measured individually. When the voltage is less than 1.4 at the point after 10ms from the point of "OFF→ON" or "ON→OFF", subsequent voltage fluctuation exceeding 1.4V shall be measured as t2. Noise voltage at the range of OFF code shall be 3.6 V min.

Customer P/N:	Toneluck P/N: MQS-9A1HC-A1	Project Code:
Version: A1	Issued Date: 2022-03-09	Page 2 of 8

5. Mechanical specification

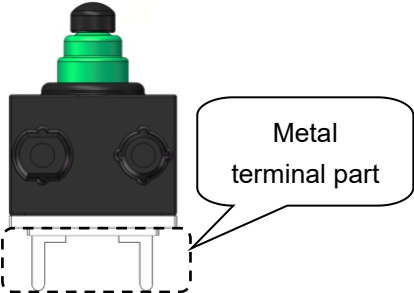
Item	Test conditions	Criteria
5.1	Operating Force A static load shall be applied to the tip of actuator in operating direction	Refer to individual product drawing
5.2	Operation Position△ When switch is being converted, the distance between the actuator midpoint (or tip of the shaft) and the datum location.	Refer to individual product drawing
5.3	Free Position The distance between the actuator midpoint (or tip of the shaft) and datum location when no external force is applied.	Refer to individual product drawing.
5.4	The degree of protection IP67 Except metal terminal part (See below drawing)	Meets DIN EN 60529 judgment standards
		
5.5	Robustness of terminal A static load of 3 N shall be applied to the tip of terminal in a desired direction for 1 min. The test shall be done once per terminal.	1. Shall be free from terminal looseness, damage and insulator breakage. 2. Item 4.1/4.2/4.3 shall be satisfied.
5.6	Robustness of actuator 1. A static load of 20 N shall be applied in the operating direction of actuator for 15s 2. A static load of 20 N shall be applied in the pull direction of actuator for 15s 3. A static load of 5 N shall be applied in the perpendicular direction of operation at the tip of actuator for 15s	Shall be free from significant wobble deformation and mechanical abnormalities
5.7	Vibration Proof Switch shall be secured to a testing machine by a normal mounting device and method. Switch shall be measured after following test. 1. Vibration frequency range:10~55 Hz 2. Total amplitude:1.5mm 3. Sweep ratio:10~55~10Hz Approx. 1 min. 4. Method of changing the sweep vibration frequency: logarithmic or linear 5. Direction of vibration: Three perpendicular directions including actuating direction. 6. Duration: 2 hours each (6 hours in total)	After test: 1. Contact resistance:1Ω Max. 2. Insulation resistance:10 MΩ Min. 3. Voltage proof: Apply 500VAC for 1 min, no dielectric breakdown shall occur. 4. Item 5.1/5.2/5.3 shall be satisfied. 5. Shall be free from mechanical abnormalities.

Customer P/N:	Toneluck P/N: MQS-9A1HC-A1	Project Code:
Version: A1	Issued Date: 2022-03-09	Page 3 of 8

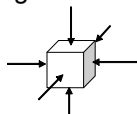
5.8	Mechanical Shock	<p>Switch shall be measured after following test :</p> <ol style="list-style-type: none"> 1. Mounting Method: Normal mounting method 2. Acceleration: 490m/s² (50G) 3. Duration: 11 ms 4. Test Direction: 6 directions  <ol style="list-style-type: none"> 5. Number of shocks: 3 times per each direction (18 times in total) 	<p>After test:</p> <ol style="list-style-type: none"> 1. Contact resistance:1Ω Max. 2. Insulation resistance:10 MΩ Min. 3. Voltage proof: Apply 500VAC for 1 min, no dielectric breakdown shall occur. 4. Item 5.1/5.2/5.3 shall be satisfied. 5. Shall be free from mechanical abnormalities.
5.9	Solderability	<p>Switch shall be checked after following test:</p> <ol style="list-style-type: none"> 1. Soldering Temperature: 260±5°C 2. Immersing Time: 3±0.5 s 3. Immersion Depth: It should be immersed up to 1.6mm from the root of terminal. 	<p>More than 90% of immersed part shall be covered with solder.</p>
5.10	Solder Heat Resistance	<p>Manual soldering: Use soldering irons(max. 360°C, within 3 seconds) capable of temperature adjustment.</p>	<ol style="list-style-type: none"> 1. No abnormalities shall be observed in appearance and operation. 2. The electrical performance requirements specified in item 4 shall be satisfied.

6. Durability

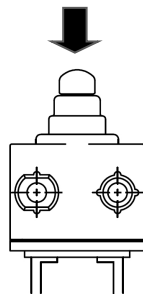
Item	Test conditions	Criteria
6.1 Operating Life without Load	<ol style="list-style-type: none"> 1. Switch shall be operated 500,000 cycles continuously at 60-100 cycles/min without load. 2. 0.3mm away from total travel position <p>Actuation Direction</p> 	<p>After test:</p> <ol style="list-style-type: none"> 1. Contact resistance:1Ω Max. 2. Insulation resistance:10 MΩ Min. 3. Item 5.1/5.2/5.3 shall be satisfied. 4. No abnormalities shall be recognized in appearance and construction. 5. Contact chattering and bouncing: 20ms Max.
6.2 Operating Life with Load	<ol style="list-style-type: none"> 1. Switch shall be operated 300,000 cycles continuously at 15-30 cycles/min with 12VDC 10mA(Resistive load) 2. Operation speed: 250mm/s 3. Actuation angle refer to: Special Note B1. 4. Test temperature:Room temperature 	<p>After test:</p> <ol style="list-style-type: none"> 1. Contact resistance:1ΩMax. 2. Insulation resistance:10MΩ Min. 3. Item 5.1/5.2/5.3 shall be satisfied. 4. No abnormalities shall be recognized in appearance and construction. 5. Contact chattering and bouncing: 20ms Max.

Customer P/N:	Toneluck P/N: MQS-9A1HC-A1	Project Code:
Version: A1	Issued Date: 2022-03-09	Page 4 of 8

7. Environmental test

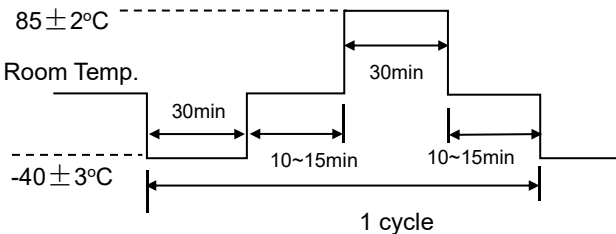
Item	Test conditions	Criteria
7.1 Cold Proof	After testing at $-40\pm 2^{\circ}\text{C}$ for 500 hours, the switch shall be allowed to stand under normal temperature and humidity conditions for 1 hour, and then measurement shall be made within 1 hour. Water drops shall be removed.	After test: 1. Contact resistance: 1Ω Max. 2. Insulation resistance: $10\text{ M}\Omega$ Min. 3. Voltage proof: Apply 500VAC for 1 min, no dielectric breakdown shall occur. 4. Item 5.1/5.2/5.3 shall be satisfied. 5. No abnormalities shall be recognized in appearance and construction.
7.2 Hot Proof	After testing at $85\pm 2^{\circ}\text{C}$ for 500 hours, the switch shall be allowed to stand under normal temperature and humidity conditions for 1 hour, and then measurement shall be made within 1 hour. Water drops shall be removed.	After test: 1. Contact resistance: 1Ω Max. 2. Insulation resistance: $10\text{ M}\Omega$ Min. 3. Voltage proof: Apply 500VAC for 1 min, no dielectric breakdown shall occur. 4. Item 5.1/5.2/5.3 shall be satisfied. 5. No abnormalities shall be recognized in appearance and construction.
7.3 Damp heat	After testing at $60\pm 2^{\circ}\text{C}$, 90~95% RH for 500 hours, the switch shall be allowed to stand under normal temperature and humidity conditions for 1 hour, and measurement shall be made within 1 hour after that. Water drops shall be removed.	After test: 1. Contact resistance: 1Ω Max. 2. Insulation resistance: $10\text{ M}\Omega$ Min. 3. Voltage proof: Apply 500VAC for 1 min, no dielectric breakdown shall occur. 4. Item 5.1/5.2/5.3 shall be satisfied. 5. No abnormalities shall be recognized in appearance and construction.
7.4 Salt mist	Switch shall be checked after following test 1. Temperature: $35\pm 2^{\circ}\text{C}$ 2. Salt solution: $5\pm 1\%$ (solids by mass) 3. Duration: 100h After the test, salt deposit shall be removed in running water.	No remarkable corrosion which is functionally harmful shall be recognized
7.5 Temperature Cycling	After 100 cycles of following conditions, the switch shall be allowed to stand under normal temperature and humidity conditions for 1 hour, and measurement shall be made within 1 hour after that. Water drops shall be removed. 	After test: 1. Contact resistance: 1Ω Max. 2. Insulation resistance: $10\text{ M}\Omega$ Min. 3. Voltage proof: Apply 500VAC for 1 min, no dielectric breakdown shall occur. 4. Item 5.1/5.2/5.3 shall be satisfied. 5. No abnormalities shall be recognized in appearance and construction.

Special Notes:

Customer P/N:	Toneluck P/N: MQS-9A1HC-A1	Project Code:
Version: A1	Issued Date: 2022-03-09	Page 5 of 8

A. General

A1. It is necessary to design circuits or software that are not affected by the bounce and chattering specified for each product.

A2. Do not operate switches continuously at extremes of high low temperatures of the specified temperature range (chapter 7.1/7.2). The maximum operating duration under the specific environmental conditions is specified in the part specifications.

A3. This product is designed and manufactured assuming that it is to be used with the resistance for direct current. If you use other kinds of resistance (inductive(L) or capacitive(C)), please let us know beforehand.

B. Mechanism design (Switch layout)

B1. Actuation Angle: Besides actuating the micro-switch vertically, the special robust actuator design allows actuation from all directions with an approach angle as less as 40°

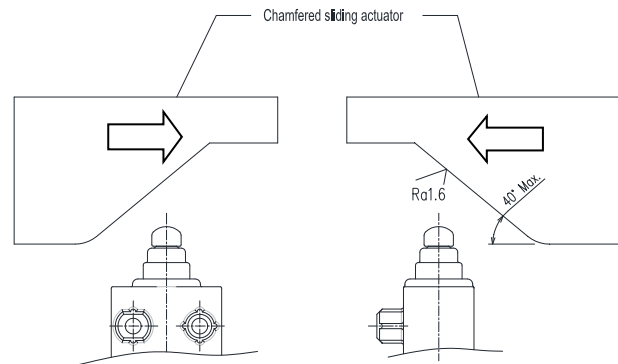

The approximate value of 40° was tested under the following conditions:

- Chamfered sliding material : POM
- Polished chamfered sliding surface, greased with Berulub FR43 or Isoflex Topas L32 .
- 0.3mm away from total travel position
- Suggest angle $\leq 30^\circ$ if no grease on sliding surface

B2. Application position recommendation:

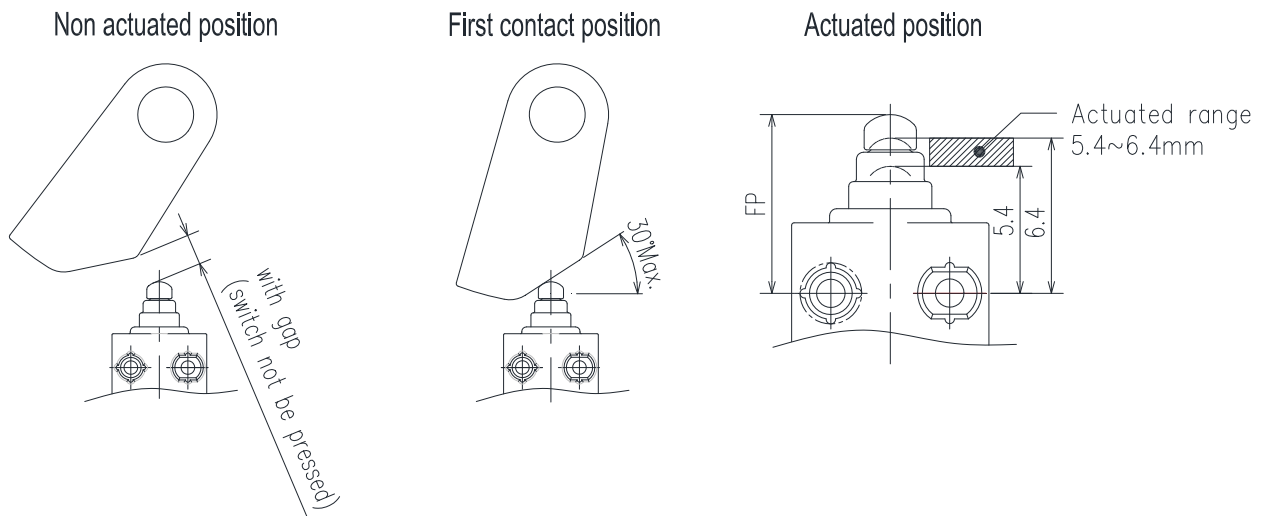

Customer P/N:	Toneluck P/N: MQS-9A1HC-A1	Project Code:
Version: A1	Issued Date: 2022-03-09	Page 6 of 8

- B3. The switch will be broken, if you give larger stress than specified (chapter 5.5/5.6). Take most care not to let the switch given with larger stress than specified.
- B4. Designing printed pattern and parts layout shall be given due consideration, because the characteristics may change by warp of P.C.B.
- B5. Care should be taken to assure that excess force is not applied on the actuator because it is small and weak when P.C.B. are stacked or transported.
- B6. Do not use return force of switches as operating force.
- B7. If you operate switches with full travel and apply force on the side of housing, the actuator will not be returned.
- B8. When using a cam or dog to operate the Switch, factors such as the operating speed, operating frequency, actuator indentation, and material and shape of the cam or dog will affect the durability of the Switch. Confirm performance specifications under actual operation conditions before using the Switch in applications.
- B9. When the product is connected to the terminal of the plate, it can only be performed once. Please do not use the product that has been inserted once and pulled from the terminal.
- B10. When conducting ultrasonic wave welding on the unit, depending on vibration direction and frequency, it may cause resonance-phenomenon with the Switch and deteriorate its performance. Depending on the Switch mounting condition and vibration direction, it may lead to contact failure such as decrease of contact pressure or abnormal abrasion. Therefore, please take enough confirmation of the influence on the Switch by mounting evaluation
- B11. When the door latch is locked, please keep the switch in free position. If you use other designs, please confirm performance specifications under actual operation conditions before using the Switch in applications.
- B12. To prevent deterioration due to soldering heat. Care should be taken not to apply force to the terminals during soldering. (More than one second interval is required to apply heat at each terminal).

C. Using environment

C1. If you use this product in one of the following environmental conditions, progress of sulfuration and oxidization on the contact part will be accelerated, which may cause contact failure. Therefore, be careful about the usage environment

- (1) Around a sulfurate hot spring where sulfide gas is generated. And in case this product is always used in a place where exhaust gas from automobiles occur
- (2) Follow the directions if you have parts/materials described below within the module where the switch is installed
 - For parts, rubber materials, adhesive agents, plywood, packing materials and lubricant used for the mechanical part of the device, do not use those ones that may generate gas of sulfurization or oxidization.
 - When you use silicon rubber, grease, adhesive agents and oil, use those that will not generate low molecular siloxane gas. The low molecular siloxane gas may form silicon dioxide coat on the switch contact part, resulting in the contact failure.

D. Storage method

- D1. If the product is not used immediately, store it as delivered at the following environment: without direct sunshine or corrosive gas at normal room temperature...However, it is recommended that you should use it as soon as possible within six months after delivery.
- D2. After you break the seal, you should put the remaining in a plastic bag to separate it from the outside and store it in the same environment mentioned above. You should use them up as soon as possible.
- D3. Do not stack too many switches.

Customer P/N:	Toneluck P/N: MQS-9A1HC-A1	Project Code:
Version: A1	Issued Date: 2022-03-09	Page 7 of 8

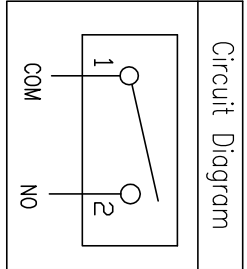
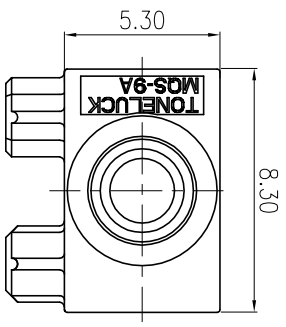

Mechanical Characteristics(Initial):	
Item	Criteria
Operating Force(OF)	180gf Max.
Free Position(FP)	7.6mm
Operation Position(OP)	7.1±0.20mm △

Electrical Characteristics:		
Ratings	Datas(resistive load)	Operating life with load
Contact Resistance:	500mΩ Max.(Initial)	300,000 Cycles Min.
Insulation Resistance:	100MΩ Min. 500VDC(Initial)	
Dielectric strength: (Initial)	500VAC(50~60HZ) - between non-connected terminals - between terminals and dead parts for one minute	

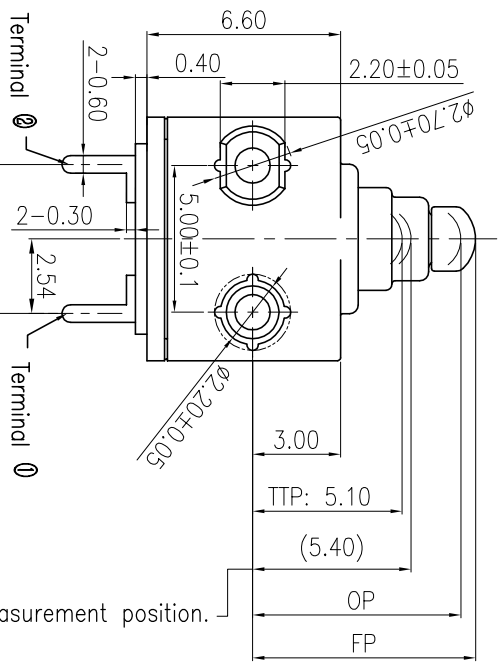

Operating force measurement position.

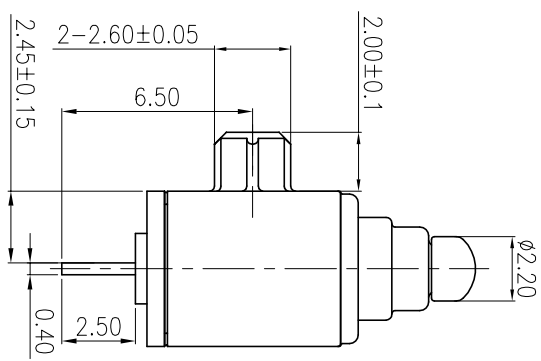

Other Spec. :	
Protection Class:	IP67(Except terminal)
Operating life without load	500,000 cycles
Operating Temperature Range:	-40℃~+85℃
Note:	Refer to specification MQS-9A1HC-A1-SPC.001
Material List	
Seal Rubber	Silicon Rubber(Green)
Switch Housing	Thermoplastics PBT
Switch Base	Thermoplastics PBT
Terminals	Copper Alloy, Silver plated
Actuator	Thermoplastics POM
Slide Contact	Copper Alloy
Spring	Stainless Steel

REV.	DATE	MODIFICATION	ECN NO.	PRIOR VERSION
Project Ref: MQS-9A SERIES MICROSWITCH				
Part No: MQS-9A1HC-A1		Tolerance Unless Otherwise Specified		
Drawing No: --	Eng Ver: A1	~3	>3-10	>10-30
Drafted by: Jerry	Date: 2021-06-15	±0.20	±0.30	±0.40
Checked by: Moon Lin	Date: 2021-06-15	±0.40	±0.60	±0.80
Approved by: Norris Xie	Date: 2021-06-15	±0.80	±1.00	±1.50

MASS PRODUCTION RELEASE

TONELOCK
Switches & Control Solutions